

2/2 direct. contr. block valve
for plate mounting

for water and oil hydraulics

DN 16 to DN 200
Operating pressures up to 320 bar

- Pilot-controlled seat valves
- Pilot-control by means of own medium
- Leakage-free sealing on valve seat
- Force-controlled working piston
- Smooth switching, no pressure shocks
- Piston is extended to the outside, there fore visible piston position
- Hydraulic or pneumatic operation possible
- Hydraulic remote control possible
- Actuation magnet protected against dirt and humidity
- Wear parts are easy to access and fast to replace
- Manual emergency operation
- Stroke limitation possible to save separate throttle valves
- Protection against accidental operation

Application

The 2/2 directional control fitted seat valves are particularly suitable for HFA liquids and clear water up to operating pressures of 320 bar maximum.

The valves can be equipped with positive or negative pilot-control valves. In a de-energized condition, this results the main valve setting "valve closed" or "valve open". The valve switching periods can be influenced by fitted filter diaphragms or intermediate plate valves with fitted fine throttles located between pilot-control and main valve. In case of valves with larger nominal widths, valve switching periods can be significantly reduced by a double pilot-control system, e.g. pilot-control valve DN 6 with intermediate plate valve DN 9, DN 12, or DN 16.

Technical data

Building type

Fitted seat valve

Pilot-control pressure

= System pressure, min. 25 bar

Control medium

Own medium

Pressure liquid

HFA acc. to CETOP or VDMA standard sheet 24320 with 95% water and 5% additives. Non-lubricated water (clear water) Mineral oil acc. to DIN 51524 and 51525 phosphoric ester

Pilot-control systems

see special brochures

Max. operating pressures

320 bar

Control medium return

Separate without pressure into tank

Flow

See table 1

Flow direction

To both sides from "A" to "B" and "B" to "A"

Liquid temperature

Main valve: coarse filtering

Pilot-control valve: 25-40 µm

Function a

Self-closing 2/2 directional control fitted seat valve, force-controlled by internally supplied own medium

Valve de-energized = rest position (closed)

The control surface 6 of piston 5 is relieved as the control hamber 7 is relieved via pilot-control valve 1 and port "L". The working medium, applied at port "A", acts on control surface 9 of piston 5. At the same time, the working medium is applied to control chamber 3, via channel 7, and to the input of the closed pilotcontrol valve 1 and acts on the control surface 4 of piston 5. Due to the force difference occurring on control surfaces 4 and 9 (control surface 4 > control surface 9), piston 5 is pressed into valve seat 8 so that infeed "A" is blocked.

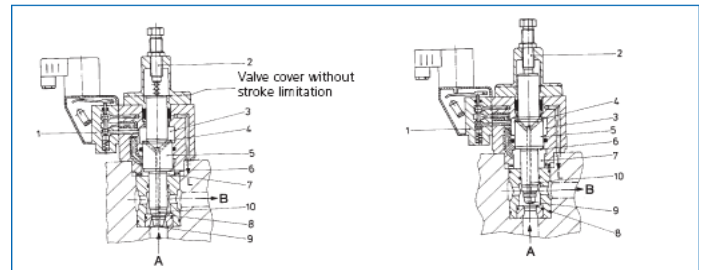
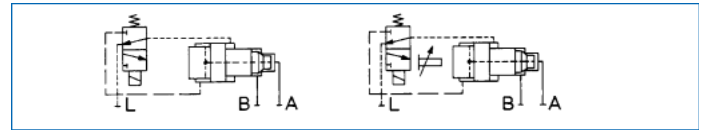

Valve de-energized
Rest position (closed)

Valve energized
Work position (open)

Valve de-energized = work position (open)

When pilot-control valve 1 is operated the passage to the control medium return line "L" is blocked, and the path from control chamber 3 to control chamber 7, via pilot-control valve 1, is released. The pressure of the control medium now acts additionally on the control surface 6 of piston 5. Due to the force difference occurring on the control surfaces 9, 6, and 4 (control surfaces 9 and 6 > control surface 4), piston 5 is lifted from valve seat 8 so that the path from infeed "A" to port "B" is now free. Every fitted valve can optionally be provided with a stroke limitation. Using adjuster screw 2, the stroke of piston 5 can be limited. Thus, there is the possibility to adapt the flow rate to the respective application situation. In the event of de-energization, the valve will close.

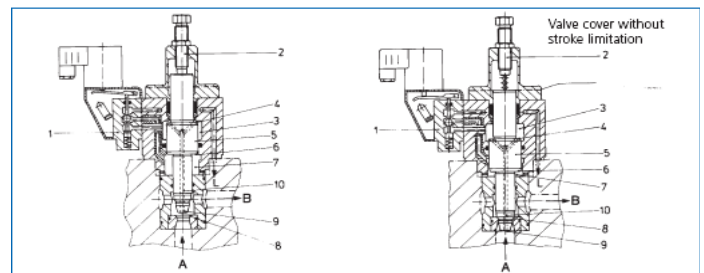
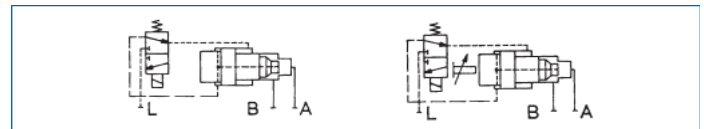

Valve energized
Work position (open)

Valve de-energized
Rest position (closed)

When mounting a negative pilot-control valve, the reversed main valve operating mode results. In the event of power failure the valve will open.

Valve de-energized = rest position (open)

The control chamber 3, to which pressure is applied, is connected to control chamber 7 via pilot-control valve 1. Due to the force difference occurring on the control surfaces 9, 6, and 4 of valve piston 5 (control surface 9 and 6 > control surface 4), piston 5 is lifted off valve seat 8. The path from "A" to "B" is clear.

Valve energized = working position (closed)

When operating pilot-control valve 1, control chamber 7 is vented via return line "L". The control surface 6 of piston 5 is relieved. Due to the force difference occurring on control surfaces 9 and 4 (control surface 4 > control surface 9) piston 5 is pressed into valve seat 8. Infeed "A" is blocked. In the event of power failure the valve will open.

Function b

Self-closing 2/2 directional control fitted seat valve, forcecontrolled by externally supplied own medium

In contrast to the valve construction type described at a the control medium is not removed from control chamber 3, but is fed into the pilot-control valve 1 externally, via port "Z". When operating the pilot-control valve 1, the path from port "Z" - via pilot-control valve 1 - direct into control chamber 7 is released, and the main valve opens. In the event of a power failure, or a control pressure collapse, the valve will close.

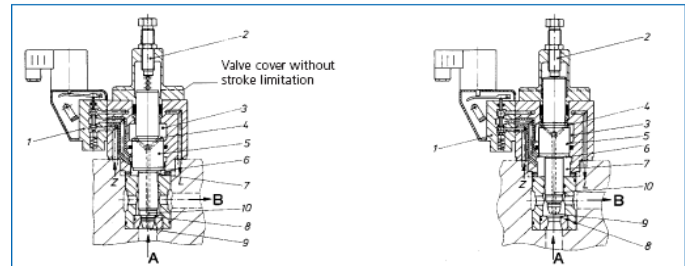
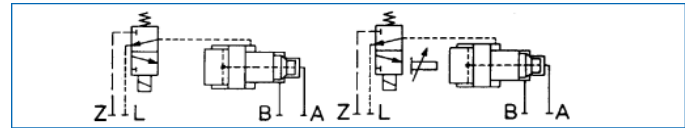

Valve de-energized
Rest position (closed)

Valve energized
Work position (open)

When using a negative pilot-control valve, the main valve operating mode reverses. In the event of a power failure the valve will open, when the pilot-control pressure collapses the valve will close.

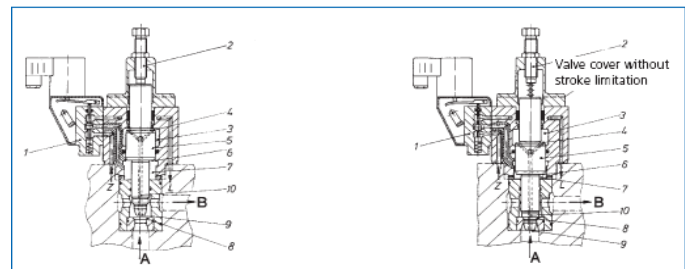
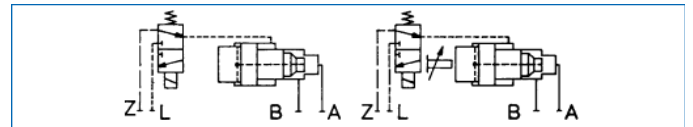

Valve energized
Work position (open)

Valve de-energized
Rest position (closed)

Function c

2/2 directional control fitted seat valve, closing and forcecontrolled by externally supplied own medium

Here to the operating mode of the main valve is the same as described at a. Only channel 10 in piston 5 does not exist. Therefore, control chamber 3 - like pilot-control valve 1 - is connected to the control port "Z", by means of which the control medium is externally supplied. In the event of power failure the valve closes; when the control pressure collapses, the valve opens.

When using a negative pilot-control valve, the main valve operating mode reverses. When there is a power failure, or the control pressure collapses, the main valve opens.

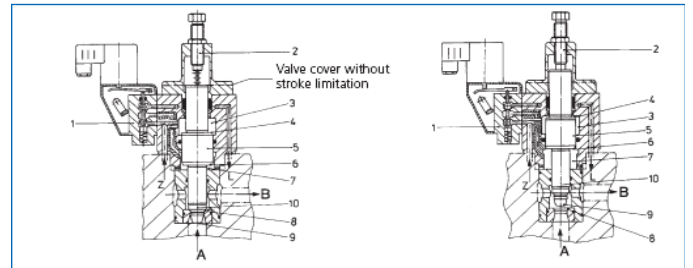
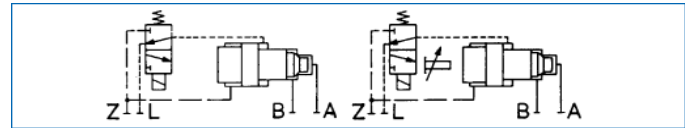

Valve de-energized
Rest position (closed)

Valve energized
Work position (open)

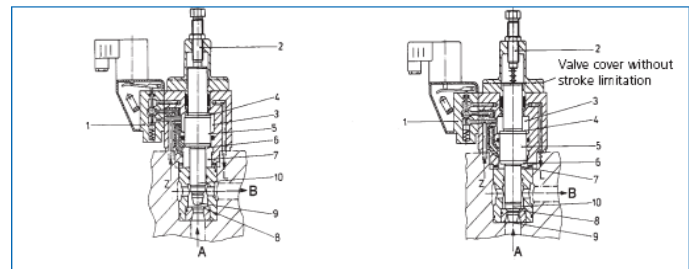
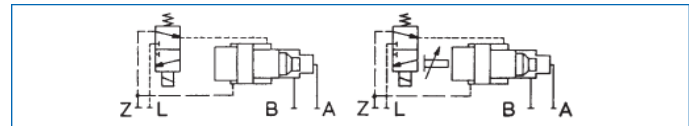

Valve energized
Work position (open)

Valve de-energized
Rest position (closed)

Function d

Force-controlled 2/2 directional control fitted seat valve closing by means of an externally supplied own medium and a further externally supplied control pressure.

The operating mode of this valve is the same as for the valve described at c. The difference between the two valves here consists in the double control pressure ports "Z" and "Z1". The pilot-control valve 1 is directly connected to the control port "Z"; control chamber 3, however, is connected to port "Z1". The control pressures on both ports are to be identical. When pilot-control valve 1 is operated, the path from port "Z" - via the pilot-control valve - directly to control chamber 7 is released, and the valve opens. For closing the valve, control pressure at port "Z"

In the event of power failure or a collapse of the control pressure at port "Z", the valve closes. When the control pressure at port "Z1" collapses, the valve opens.

When using a negative pilot-control valve, the main valve operating mode reverses. When there is a power failure, or the control pressure at port "Z1" collapses, the valve opens. If the control pressure at port "Z" collapses, the valve closes.

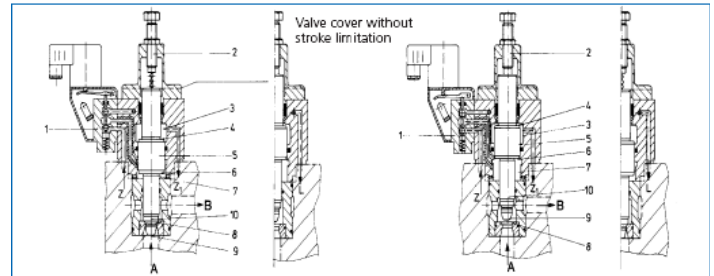
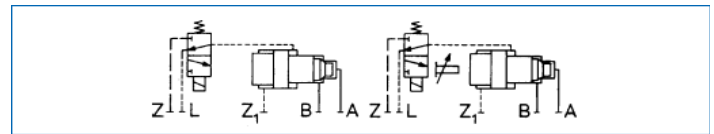

Valve de-energized
Rest position (closed)

Valve energized
Work position (open)

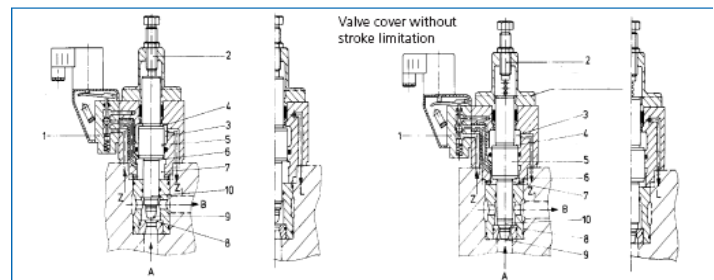
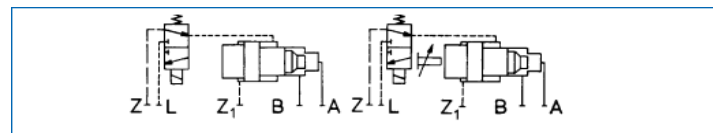

Valve energized
Work position (open)

Valve de-energized
Rest position (closed)

TIEFENBACH

Wasserhydraulik

Water-hydraulics . Systems . Valves . Valve-magnets . Spare parts . Repairs

Dimensional drawing and fitting dimensions

DN	A	B	Z	Z ¹	L	a	b	c	d	e	f	g	h	i	k	l	m	n	o	p	s	t	u*	sw	sw ¹
16	ø16	ø16	ø3,3	ø3,3	ø3,3	70	70	85	43	164	14	102	ø69	45	107	ø32	40	15	17	21	ø40	65	95	17	17
20	ø20	ø20	ø3,3	ø3,3	ø3,3	85	85	85	68	191	20	102	ø84	45	107	ø43	40	15	17	21	ø50	82	110	17	17
25	ø25	ø25	ø6	ø6	ø6	95	95	95	68	208	20	115	ø93	53	133	ø43	50	15	17	21	ø56	95	120	17	17
32	ø32	ø32	ø6	ø6	ø6	120	120	100	85	247	25	115	ø118	53	133	ø52	50	20	23	28	ø70	120	131	24	24
40	ø40	ø40	ø8	ø8	ø8	150	150	112	98	283	30	115	ø148	50	133	ø65	50	28	31	37	ø85	140	151	30	30
50	ø50	ø50	ø9	ø9	ø9	175	175	131	120	341	40	115	ø173	58	133	ø72	50	30	33	40	ø100	160	178	35	35
65	ø65	ø65	ø9	ø9	ø9	220	220	155	150	415	50	165	ø218	68	133	ø95	50	45	47	57	ø130	195	210	55	65
80	ø80	ø80	ø9	ø9	ø9	280	280	190	175	480	55	165	ø278	83	133	ø120	50	40	42	52	ø160	210	254	65	75
100	ø100	ø100	ø16	ø16	ø16	350	350	225	200	590	65	185	ø348	120	133	ø160	90	55	57	57	ø200	270	310	75	85
125	ø125	ø125	ø16	ø16	ø16	400	400	255	235	610	70	185	ø398	123	133	ø125	90	55	57	67	ø240	305	335	ø17	ø110
150	ø150	ø150	ø16	ø16	ø16	450	450	290	270	725	80	185	ø448	150	133	ø275	90	50	52	62	ø280	360	395	ø21	ø165
175	ø175	ø175	ø16	ø16	ø16	500	500	330	305	830	90	185	ø498	165	133	ø260	90	60	62	72	ø320	415	450	ø26	ø180
200	ø200	ø200	ø16	ø16	ø16	575	575	375	360	960	100	185	ø573	190	133	ø305	90	65	70	80	ø370	460	520	ø31	ø220

DN	a ₁	b ₁	c ₁	d ₁	e ₁	f ₁	g ₁	H7 ø h ₁	H7 ø i ₁	k ₁	l ₁	m ₁	n ₁	o ₁	p ₁	q ₁	r ₁	s ₁	t ₁	u ₁	v ₁	w ₁	Flansch- dichtung Z,Z ¹ L	Steuer- volumen cm	Nenn- größen der Steuer- ventile**		
16	ø70	ø70	ø58	13	ø12	M10	90°	45	40	ø42	1	2,5	15	2	41	48	16	65	15°	-	-	-	-	3,5xø1,9 NER 90 Sh	5,8	3	
20	ø96	ø85	ø70	19	ø14	M12	90°	56	50	ø52	1	2,5	20	3	53	62	20	82	15°	-	-	-	-	3,5xø1,9 NER 90 Sh	13,9	3	
25	ø100	ø95	ø78	22	ø14	M12	90°	60	56	ø59	1	3	25	3,5	61	72,5	25	95	15°	-	-	-	-	6x12x1,9 NER 90 Sh	17,9	6	
32	ø122	ø120	ø100	26	ø22	M22	90°	80	70	ø72	1	4	30	5	76	91	32	120	15°	-	-	-	-	6x12x1,9 NER 90 Sh	39,5	6	
40	ø155	ø150	ø124	30	ø26	M26	90°	95	85	ø88	1	4	35	5	91	110	40	140	15°	-	-	-	-	8x14x1,9 NER 90 Sh	61,8	6	
50	ø176	ø175	ø144	36	ø32	M30	90°	110	100	ø105	1	5	40	5	101	125	50	160	15°	-	-	-	-	10x16x1,9 NER 90 Sh	122,5	6	
65	ø223	ø220	ø186	41	ø38	M36	90°	150	140	H7 ø130	2	5	45	5	117	155	5	195	15°	-	-	-	-	10x16x1,9 NER 90 Sh	267,0	6/9	
80	-	ø280	ø230	41	ø38	M36	90°	180	170	H7 ø160	2	5	45	5	128	170	5	210	15°	220	140	-	-	10x16x1,9 NER 90 Sh	653,0	6/9	
100	-	ø350	ø280	43	ø44	M42	-	220	210	H7 ø200	2	5	50	5	167	220	5	270	15°	276	180	-	-	16x23,8x2,1 NER 90 Sh	1000	6/16	
125	-	ø400	ø340	48	ø50	M48	-	265	255	H7 ø240	2	6	55	6	177	245	6	305	15°	320	200	-	-	16x23,8x2,1 NER 90 Sh	1400	6/16	
150	-	ø450	ø380	53	ø44	M42	-	310	295	H7 ø280	2	8	60	8	217	295	8	360	15°	380	180	300	-	-	16x23,8x2,1 NER 90 Sh	1900	6/16
175	-	ø500	ø430	58	ø50	M48	-	350	340	H7 ø320	2	8	65	8	247	340	8	415	15°	426	210	340	-	-	16x23,8x2,1 NER 90 Sh	2850	6/16
200	-	ø575	ø500	63	ø58	M56	-	400	385	H7 ø370	2	10	70	10	267	375	10	460	15°	490	255	410	-	-	16x23,8x2,1 NER 90 Sh	4240	6/16

If the switching periods of the fitted seat valves are too short, single pilot-controls DN 6 can be selected instead of the double pilot-controls DN 6/9.

For the same reason, the double pilot-controls DN 6/16 can be constructed as DN 6/12.

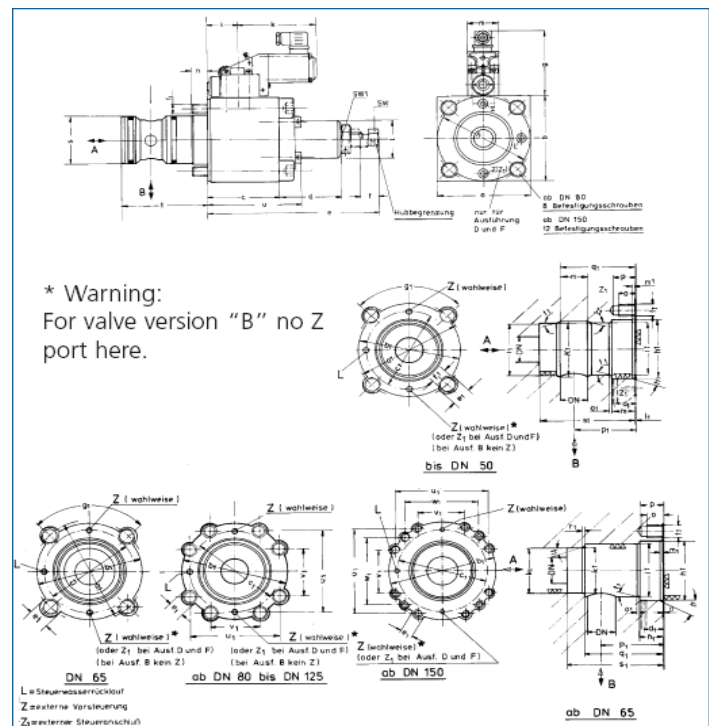

Pressure difference and volume flow

for water (20° C) in 2/2 directional control fitted seat valves

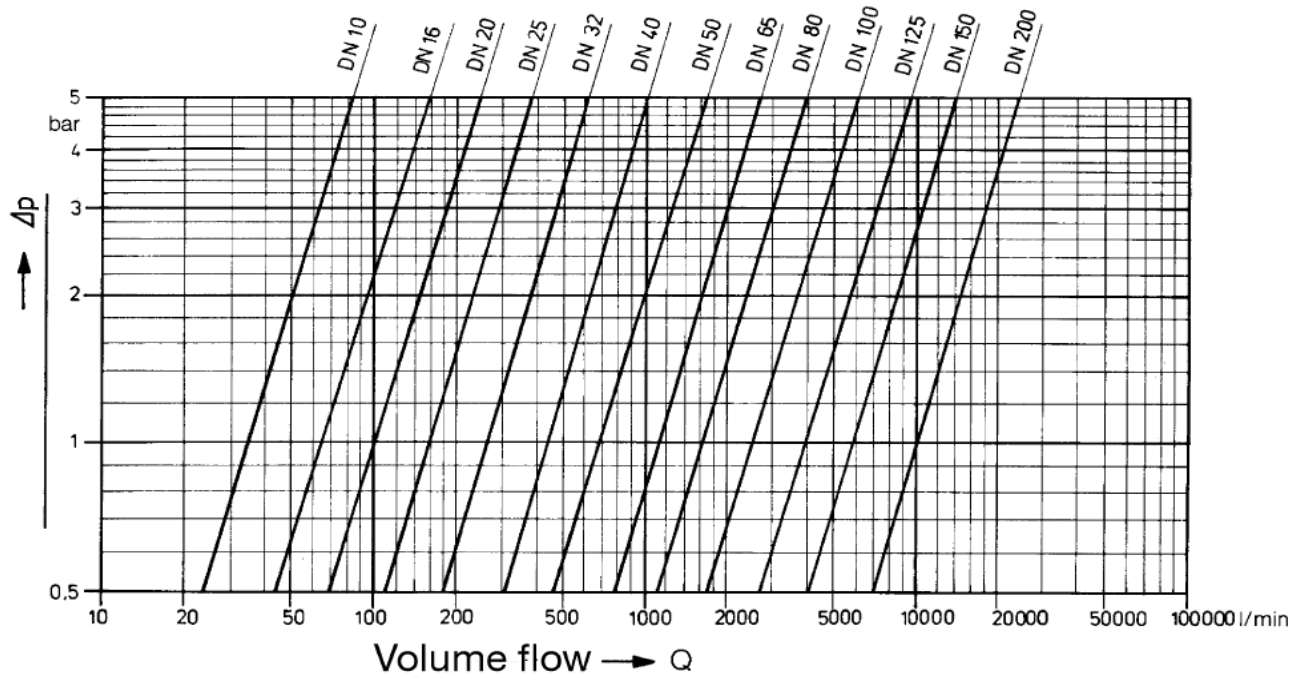

Special features

Due to the hydraulic force-control by means of the different size control surfaces of the piston rods, the piston rods cannot flutter. Closing springs are not required, thus there can be no uncontrolled piston position in the event of any spring fracture. The valves are insensitive against vibrations and pressure surges in the hydraulic system.

All wear parts are easy to access and fast to replace.

Due to the extended piston guides, the pistons cannot be tilted by crossflow action. Depending on the version, the valves are kept closed by the applied system pressure. If the pilot-control medium or the electrical power fails, the valves will close. Therefore, uncontrolled load movements cannot occur.

For a flow direction from A to B, due to the special purpose design of the valve seats and the throttle cones on the pistons, the metallic sealing surfaces are largely insensitive against dirt. This also prevents the feared switching surges.

The individual valve pistons are always extended to the outside; this causes the open or closed valve positions to be visible from the outside. There is the possibility for mounting limit switches onto the piston position indicator. Valves with stroke limitation feature appropriate bores for controlling the piston position within the stroke limitation housing.

All valve components coming into contact with one another due to their movement are made of corrosion resistant materials. For aggressive media, the complete valve can be manufactured from appropriately selected special steels.

The pilot-control valves are made completely of stainless materials. The emergency manual controls fitted as standard can be arrested and are protected against accidental activation.