

2/2 direct controlled auxiliary pressure valve

for water and oil max. 320 bar

- High switching precision
- Wear parts are easy to access and fast to replace
- Easy assembly by plate mounting
- Can also be used as a piston drop protection device

Application

The direct acting auxiliary pressure valves are used for the pressure-dependent connecting of a second pressure system as well as for keeping a pressure line open after a preset control pressure is reached. They can also be used as piston drop protection devices which closes when pressure in the system drops below a specified value.

is applied at port "Z", which keeps the valve open. The work cylinder may be moved in both directions by the control system. If pressure on port "Z" collapses below a specific preset value, then the closing spring will press the working piston of the valve into the valve seat. The valve is closed. An uncontrolled downward movement of the load is not possible. The load pressure applied at port "A" keeps the valve closed - in addition to the closing spring. Only when the pressure increases again at port "Z" will the valve open.

Function

The auxiliary pressure valve essentially comprises the housing 1, the pressure surface balanced working piston 2, a control piston 3 which can be made to various different sizes, and an adjustable plate spring column 4. The cut-in pressure is effected by means of an appropriately large control piston in combination with the adjustable spring. In its depressurized basic position the spring column presses the working piston into the seat. As long as there is no control pressure "P2" being applied at the control piston via "Z" - an opening of the valve by the working piston will not take place, even if the permissible pressure "P1" is reached at pressure port "P". The valve remains blocked. However, if the control pressure "P2" reaches a specified value on the control piston opposite the spring column (via "Z"), the control piston shifts and acts against the working piston and the spring column. The connection from "P" to "A" opens. In order to check the control pressure

"P2" the control pressure chamber is provided with a miniature measurement port. If the pressures "P1" and "P2" are to be identical, then a relevant connection is to be provided in the connection plate. When used as a piston drop protection device, a specified control or system pressure

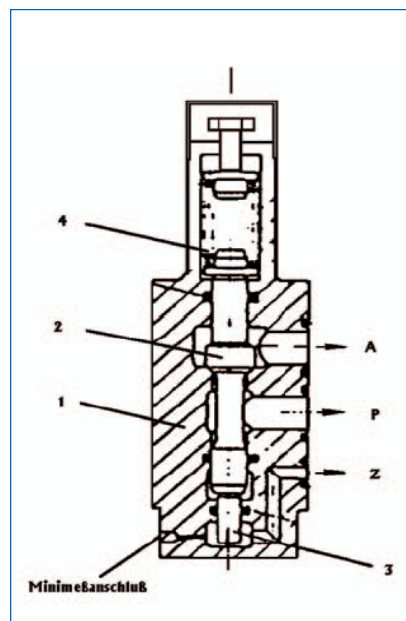

Function diagram

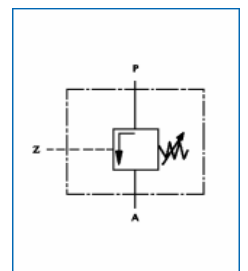

Switching symbol

Technical data

Type

Cone seat valve

Mounting

Plate mounting

Line connections

Via mounting plate

Mounting position

any

Sealing on the conn. surface

O-ring, flange seal

Max. op. pressure

360 bar

Seal on seat

Metal to metal

Fluid temperature

5°C to 55°C

Flow direction

For high pressure cut-in from "P" to "A", otherwise freely select

Order code

ZV	..	-	.	.	V	-	X
1	2		3	4	5		6

1) ZV = Designation letters for aux. pressure valve

2) .. = Nominal size of valve

3) . = Control medium:

- 1 = Water
- 2 = Oil
- 3 = Air
- 4 = Gas

4) . = Contr. pressure:

- 1 = 12 to 25 bar
- 2 = 20 to bar
- 3 =
- 4 =
- 5 =
- 6 = 360 bar

5) V = Viton, without designation = perbunan

6) X = special version in plain text

Dimensional drawing

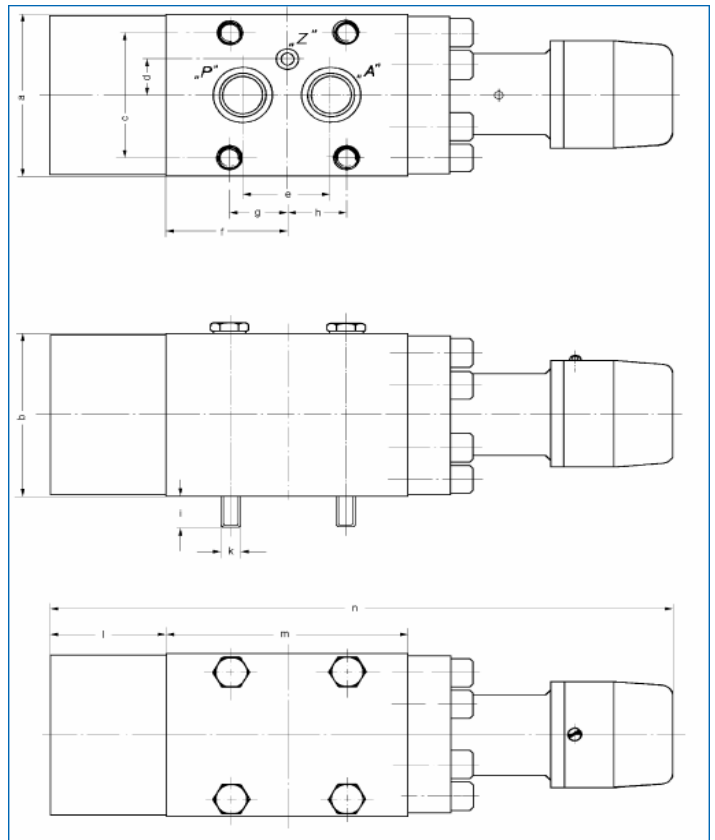

Special features

The auxiliary valve responds without delay when the preset control pressure "P2" is reached. It can be hydraulically or pneumatically driven at different pressure levels. At each pressure level it can be adjusted continuously and finely on the plate spring column. A possible lead seal protects against unauthorized tampering with the adjustment.

A	P	Z
15*2,5	15*2,5	6*2
19*2,5	19*2,5	6*12*1,9
30*3	30*3	8*2

Table:

NW	A Ø	P Ø	Z Ø	a	b	c	d	e	f	g	h	i	k	l	m	n
12	12	12	4,2	80	80	55	14	30	45	20	20	10	M 10	50	90	250
16	16	16	6	95	95	72	17,5	40	67	29	21	15	M 10	68	121	331
25	25	25	6	105	105	80	23	55	72,5	32,5	32,5	25	M 12	70	145	375