



2/2 directional control  
seat valve  
3/2 directional control  
seat valve  
NW3 and NW6  
for gases

max. 100 bar for plate mounting

- Protection against accidental operation
- Operating magnet protected against dirt and humidity

- Operating elements can each be rotated through 90°
- Wear parts are easily accessible and can be replaced quickly

### Application

The valves are used for water or oil hydraulic control systems. They can also be used as pilot-control valves.

### Fitted position

Any

### Technical data

### Flow direction

2/2W: From "P" to "A"

3/2W: From "P" to "A" or from "A" to "R"

The connections "P", "A", and "R" must not be mixed up

### Type

Direct controlled ball seat valve

### Kv value

NW 6: 6,5 l/min.

NW 3: 1,2 l/min.

### Connections

Plate mounting with O-ring seal on request available with connection plate

Connection thread

NW3 = R1/4" or 1/4" NPT

NW6 = R3/8" or 3/8" NPT

### Materials

All parts coming into contact with the flow medium are made of corrosion resistant materials

### Medium:

Compressed air and gases

### Operating modes

Electric, hydraulic, pneumatic, mechanical or manual operation

### Viscosity

1 to 300 cSt

### Special features

The valve is characterized by fast response times. The solenoid plunger of the electromagnet is dual-supported and thus protected against wear. By means of a diaphragm seal between the pushrod and the solenoid plunger chamber the control electromagnet is protected against dirt and humidity. The arrestable manual operation device can be accessed by removing the type plate and is thus also protected against any accidental operation. The electric magnet and all other control elements can each be rotated through 90°. All wear parts are easily accessible and quick to replace.

### Ambient temperature

Depends on control element, see table "Technical data of control elements", higher temperatures on request

### Seals

NBR, other seal materials available upon request

### Sealing

Ball on seat

### Pressure range

0 to 100 bar for 3/2 dir.:

The pressure in connection "R" must not exceed 50% of working pressure

### Switching time

Depends on operating pressure and operating temperature (see table: technical data of control elements)

### Valve version "positive"

(Valve is closed when magnet is de-energized)

Fig. 1 (electromagnet de-energized):

The pressure spring (2) presses the valve ball (4) via pushrod (3) into the valve seat (5). The pressure of the medium in infeed "P" supports the pressure spring action (2). Thus the passage from infeed "P" to working line "A" is blocked.

Fig. 2 (electromagnet energized):

When the electromagnet (1) is switched on, the solenoid plunger (6) presses the valve ball (4) - via lever (7) and pushrod (8), and against the force of the pressure spring (2) and the pressure of the medium in the infeed "P" - from its valve seat (5). Now the passage from infeed "P" to working line "A" is clear.

electromagnet de-energized      electromagnet energized

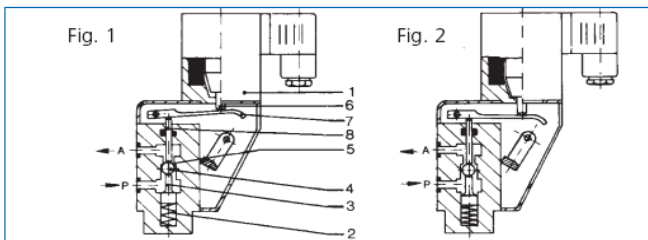

A	working line	4	valve ball
B	infeed	5	valve seat
1	electromagnet	6	solenoid plunger
2	pressure spring	7	lever
3	pushrod	8	pushrod

### Valve version "negative"

(Valve is open when magnet is de-energized)

Fig. 1 (electromagnet de-energized):

The pressure spring (2) lifts the valve ball (4) via pushrod (3) from the valve seat (5). Thus the passage from infeed "P" to working line "A" is clear.

Fig. 2 (electromagnet energized):

When the electromagnet (1) is switched on, the solenoid plunger (6) presses the valve ball (4) - via lever (7) and pushrod (8), and against the force of the pressure spring (2) and the pressure of the medium in the infeed "P" - into the valve seat (5). Now the passage from infeed "P" to working line "A" is blocked.

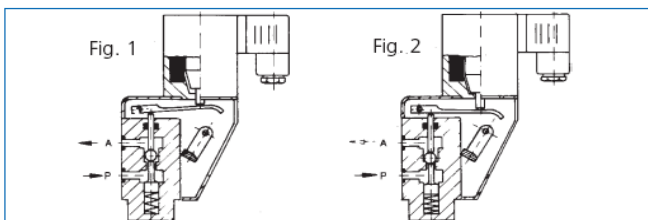

A	working line	4	valve ball
B	infeed	5	valve seat
1	electromagnet	6	solenoid plunger
2	pressure spring	7	lever
3	pushrod	8	pushrod

### Type and Order example

Operating modes	Symbol	Type: NW3
Electromagnetic Example for 24 volts		2/2KSV-03P-25NBNNN-ED024* 2/2KSV-03N-25NBNNN-ED024**
Hydraulic		2/2KSV-03P-25NBGNN-Z320* 2/2KSV-03N-25NBGNN-Z320**
Pneumatic		2/2 KSV-03P-25NBGNN-Z064* 2/2 KSV-03N-25NBGNN-Z064**
Mechanical (roller)		2/2KSV-03P-25NBGNN-RO* 2/2KSV-03N-25NBGNN-RO**
Manual		2/2KSV-03P-25NBGNN-MAN* 2/2KSV-03N-25NBGNN-MAN**
		<b>Type: NW6</b>
Electromagnetic Example for 24 volts		2/2KSV-06P-25NBNNN-ED024* 2/2KSV-06N-25NBNNN-ED024**
Hydraulic		2/2KSV-06P-25NBGNN-Z320* 2/2KSV-06N-25NBGNN-Z320**
Pneumatic		2/2 KSV-06P-25NBGNN-Z064* 2/2 KSV-06N-25NBGNN-Z064**
Mechanical (roller)		2/2KSV-06P-25NBGNN-RO* 2/2KSV-06N-25NBGNN-RO**
Manual		2/2KSV-06P-25NBGNN-MAN* 2/2KSV-06N-25NBGNN-MAN**

dimensional drawing

dimensions shown outside brackets DN 6

dimensions shown in brackets DN 3

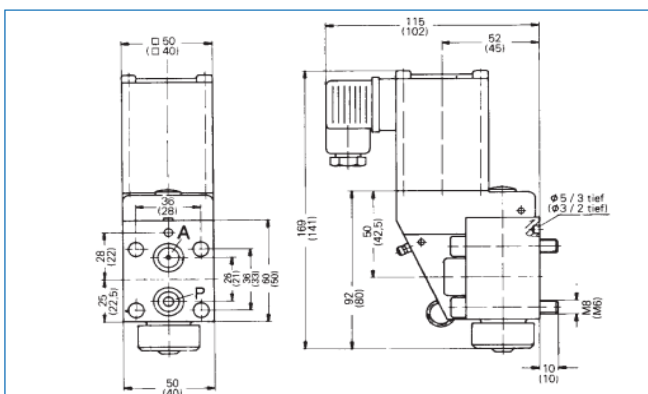

\* Version "positive" = closed de-energized

\*\* Version "negative" = open de-energized



	NW3 infeed + working line	NW6 infeed + working line
connection bore	3	6
O-ring	9,25*1,78	12*2,5

### Valve version "positive"

(Valve passage from "P" to "A" is closed when magnet is deenergized)

Fig. 1 (electromagnet de-energized):

The medium fed in via infeed "P" presses the valve ball (4) into the valve seat (5), supported by the pressure spring (2). Thus the passage from infeed "P" to working line "A" is blocked.

Fig. 2 (electromagnet energized):

When the electromagnet (1) is switched on, the solenoid plunger (8) presses the valve ball (6) - via lever (9) and pushrod (10), and against the force of the pressure spring (2) - into the valve seat (7). Now drain "R" is blocked. At the same time, using the spacer pin (3), the valve ball (4) is pressed out of the valve seat (5), so that the passage from infeed "P" to working line "A" is now clear.

electromagnet de-energized      electromagnet energized

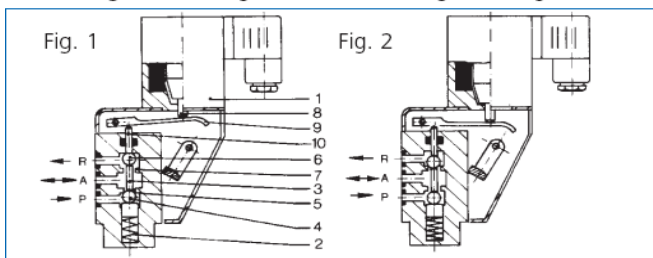

- P = infeed
- A = working line
- R = return
- 1 electromagnet
- 2 pressure spring
- 3 spacer pin
- 4 valve ball
- 5 valve seat
- 6 valve ball
- 7 valve seat
- 8 solenoid plunger
- 9 lever
- 10 + 11 pushrod

### Valve version "negative"

(Valve passage from "P" to "A" is open when the magnet is deenergized)

fig. 1 (electromagnet de-energized)

The pressure spring (2) lifts the valve ball (4) via pushrod (11) into valve seat (5). The medium flowing from infeed "P" to the working line supports the pressure spring action. Thus the drain "R" is blocked and the infeed "P" is connected to the working line "A".

Fig. 2 (electromagnet energized) When the electromagnet (1) is switched on, the solenoid plunger (8) presses the valve ball (4) - via lever (9) and pushrod (10), and against the force of the pressure spring (2) and the pressure of the medium in the infeed "P" - into the valve seat (7). Now the infeed "P" is blocked and the working line "A" is connected to drain "R".

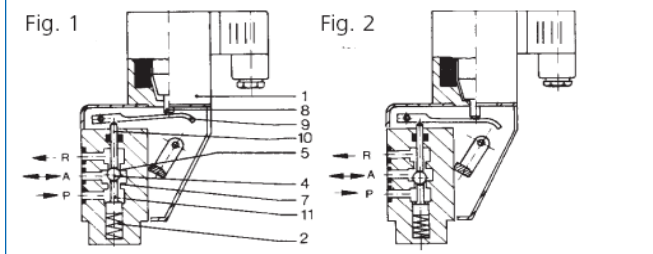

- P = infeed
- A = working line
- R = return
- 1 electromagnet
- 2 pressure spring
- 3 spacer pin
- 4 valve ball
- 5 valve seat
- 6 valve ball
- 7 valve seat
- 8 solenoid plunger
- 9 lever
- 10 + 11 pushrod

dimensional drawing DN 3 and DN 6  
DN 3 dimensions shown in brackets      P = infeed  
A = working line  
R = return

### Type and Order example

Operating modes	Symbol	Type: NW3
Electromagnetic Example for 24 volts		3/2KSV-03P-25NBNNN-ED024* 3/2KSV-03N-25NBNNN-ED024**
Hydraulic		3/2KSV-03P-25NBGNN-Z320* 3/2KSV-03N-25NBGNN-Z320**
Pneumatic		3/2 KSV-03P-25NBGNN-Z064* 3/2 KSV-03N-25NBGNN-Z064**
Mechanical (roller)		3/2KSV-03P-25NBGNN-RO* 3/2KSV-03N-25NBGNN-RO**
Manual		3/2KSV-03P-25NBGNN-MAN* 3/2KSV-03N-25NBGNN-MAN**
		<b>Type: NW 6</b>
Electromagnetic Example for 24 volts		3/2KSV-06P-25NBNNN-ED024* 3/2KSV-06N-25NBNNN-ED024**
Hydraulic		3/2KSV-06P-25NBGNN-Z320* 3/2KSV-06N-25NBGNN-Z320**
Pneumatic		3/2 KSV-06P-25NBGNN-Z064* 3/2 KSV-06N-25NBGNN-Z064**
Mechanical (roller)		3/2KSV-06P-25NBGNN-RO* 3/2KSV-06N-25NBGNN-RO**
Manual		3/2KSV-06P-25NBGNN-MAN* 3/2KSV-06N-25NBGNN-MAN**

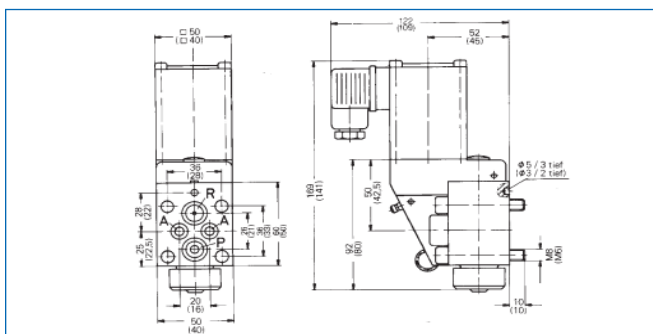

\* Version "positive" = closed de-energized  
\*\* Version "negative" = open de-energized



	NW3			NW6		
	P	R	A	P	R	A
connection bore	Ø3	Ø3	Ø3	Ø3	Ø3	Ø3
O-ring	9,25	9,25	6,07	12-	12-	8-2
	1,78	1,78	1,78	2,5	2,5	

### Valve body with console

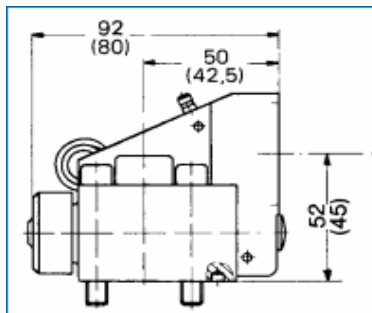

### Hydraulic and pneumatic operation

Pressure range:  
 Pneumatic 2,5-64 bar  
 Hydraulic 2,5-64 bar  
 22-320 bar

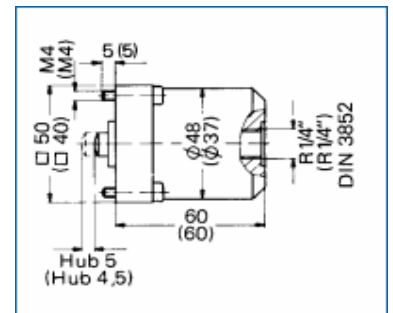

### Mechanical operation

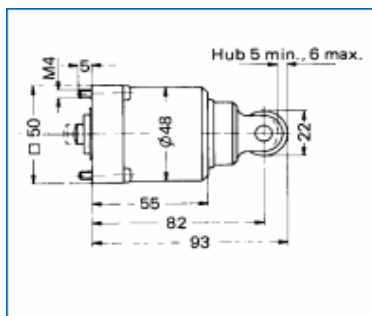

### Manual operation

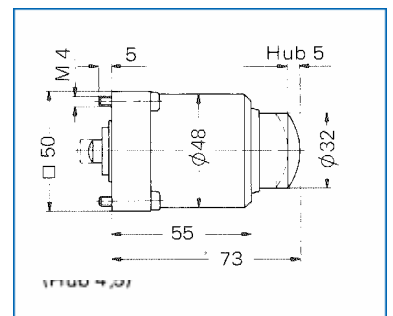

### Electro magnetic operation NW3 and NW6, firedamp-proof and explosion-proof

type dE4 (NW3) and dE3 (NW6), protection class acc. to VDE 0170/0171

#### NW3:

(Sch)d/(Ex)d2 G4 Besch.-Nr. T5681/BVS

#### NW6:

(Sch)d/(Ex)d2 G5 Besch.-Nr. T5538/BVS

NW3/Pg 16 DIN 22419 available for voltages from 12 - 240 V direct and alternating current.

*power consumption*  
 up to approx. 20 Watt

#### connection cable

12,5 - 14 mm (A15) NW6/Pg 21 DIN 22419 available for voltages from 24 - 500 V direct and alternating current.

*power consumption*  
 up to approx. 32 Watt

#### connection cable

15 - 19 mm (A19)

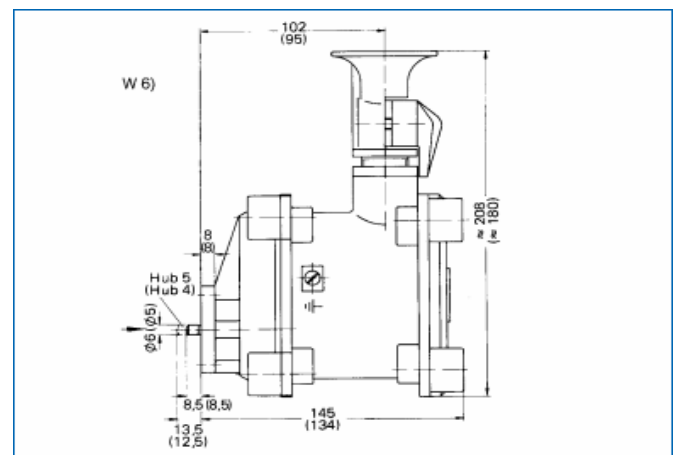
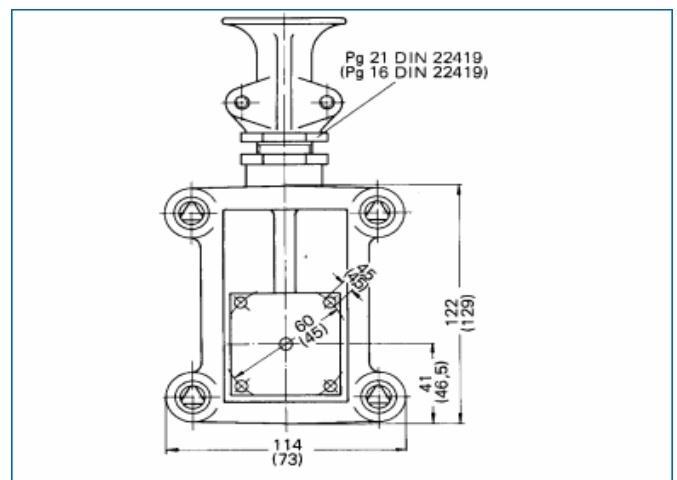

actuator	NW3						
design type	electro magnet				hydraulic our pneumatic cylinder		roller actuation
			dE4	dE4	Zyl. 31295	Zyl. 31887	
protection class housing	IP 54 DIN 40050	IP 54 DIN 40050	(Sch)d/(EX)d2G4V DE 170/0171	(Sch)d/(EX)d2G4V E 170/0171			
protection class connection compartment			Sch)e/(Ex)eVDE 0170/0171IP 54DIN 40050	(Sch)e/(Ex)eVDE 0170/0171IP 54DIN 40050			
connection type	plug	plug	terminal	terminal	thread R1/4"	thread R1/4"	
control medium					oil in water emulsion, compressed air and neutral gases	oil in water emulsion,	
medium temperature					-30° C bis +110° C	-30° C bis +110° C	
ambient temperature	max.+35°C	max.+35°C	max.+40°C	max.+40°C	max.+80°C	max.+80°C	max.+80°C
pressure range					2,5-64 bar	25-320 bar	
mounting position	any	any	any	any	any	any	any
operating voltage*	24 V=	220 V ~	24 V=	220 V ~			
current intensity	0,54 A	0,06 A	0,54 A	0,06 A			
switch-on period	100% ED	100% ED	100% ED	100% ED			
pull-in power	13 W	13 W	13 W	13 W			
hold performance	13 W	13 W	13 W	13 W			
on period (100 bar)							
off period							
lifting force	31 N	26 N	31 N	26 N			

\* Other voltages possible

### Connection plate 3/2 way NW3 and NW6

Dimensions in brackets NW3

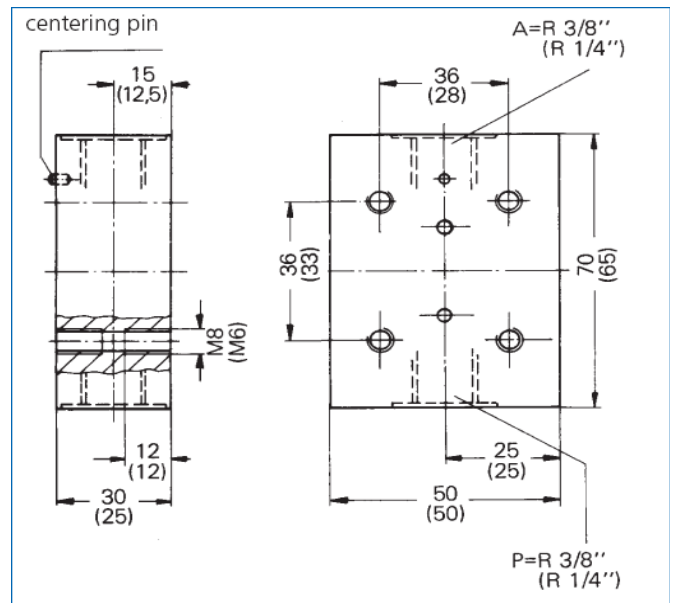
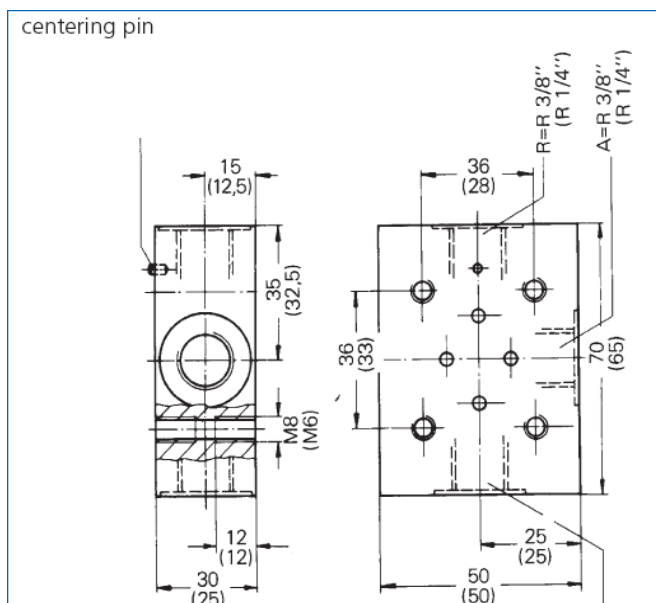

# TIEFENBACH

## Wasserhydraulik

actuator	NW6						
design type	electro magnet				hydraulic our pneumatic cylinder	roller actuation	
			dE3	dE3	Zyl. 31110	Zyl. 31136	mech. 31099
protection class housing	IP 54 DIN 40050	IP 54 DIN 40050	(Sch)d/(EX)d2G4V DE 170/0171	(Sch)d/(EX)d2G4VD E 170/0171			
protection class connection compartment			Sch)e/(Ex)eVDE 0170/0171 IP 54 DIN 40050	(Sch)e/(Ex)eVDE 0170/0171 IP 54 DIN 40050			
connection typ	plug	plug	terminal	terminal	thread R1/4"	thread R1/4"	
control medium					oil in water emulsion, compressed air and neutral gases	oil in water emulsion,	
medium temperature					-30° C bis +110° C	-30° C bis +110° C	
ambient temperature	max.+35°C	max.+35°C	max.+40°C	max.+40°C	max.+80°C	max.+80°C	max.+80°C
pressure range					2,5-64 bar	25-320 bar	
mounting position	any	any	any	any	any	any	any
operating voltage*	24 V=	220 V ~	24 V=	220 V ~			
current intensity	1,5 A	0,163 A	0,542 A	0,1318 A			
switch-on period	100% ED	100% ED	100% ED	100% ED			
pull-in power	36 W	36 W	13 W	13 W			
hold performance	36 W	36 W	13 W	13 W			
on period (100 bar)	83 ms	73 ms	112 ms	124 ms			
off period	20 ms	113 ms	24 ms	80 ms			
lifting force	93 N	79 N	58 N	54 N			

### Connection plate 3/2 way NW3 and NW6

Dimensions in brackets NW3

